



THE FLO KING LOW-PROFILE BXL5000



**Over
the
Side!**

- **EXTENDS JUST 2" (5 cm) ABOVE THE TANK**
- **FOR BARREL, AUTOMATIC, AND OTHER OPERATIONS WITH LIMITED CLEARANCE OVER TANK**
- **CAN BE MOUNTED ON TANK FLANGE OR LIP UP TO 6" (15 cm) WIDE**
- **PROVIDES A FLOW RATE OF 5,000 GPH (19,000 LPH)**
- **BUILT IN SEVERAL LENGTHS FOR MANY TANK CONFIGURATIONS**
- **AN ALTERNATIVE TO AIR OR MECHANICAL AGITATION**
- **NOW WITH IMPROVED BELT-DRIVE SYSTEM**
- **COMPLETE, PREASSEMBLED, READY TO OPERATE. NO PLUMBING. NO COSTLY INSTALLATION. OUT OF THE BOX AND INTO YOUR TANK!**

The BXL5000 is an extension of our popular BXL2500 technology with "over-the-side" motor to avoid above-tank obstructions. This unique model provides filtration and agitation for even larger tanks. Plus, our Long Motor Base design permits installation on tanks with mounting surfaces as wide as 6" (15 cm)!

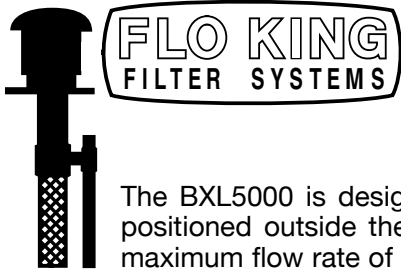

IN-TANK TECHNOLOGY



THE FLO KING BXL5000

The BXL5000 is designed for tanks where overhead clearance is limited. The motor is inverted and positioned outside the tank, taking up only 2" (5 cm) of space above the tank. The unit provides a maximum flow rate of 5000 gallons per hour. Use it stationary on one tank or move it from tank to tank. Multiple body lengths (8", 10", 12", and 14") enable use of the BXL5000 in tanks with varying solution levels and depths. The BXL5000 comes ready to operate and includes the items shown in the labeled photograph below. For best results in most metal-finishing solutions, use the BXL5000 with our PMCA Permacore Magnum reusable or FK50 Poly-Spun disposable filter cartridges in the appropriate length.

FLO KING BXL5000 SPECIFICATION

PUMP MATERIALS: Available in CPVC, polypropylene, PVDF (Kynar), and stainless steel (see Bulletin 23.5) as pump materials of construction. Standard shaft is made of Teflon-covered 303 stainless steel. A titanium-tip or Hastelloy-C276-tip shaft is available on special-order basis. Call for prices.

FLOW RATE: 5000 gallons per hour (19,000 liters per hour) at 60 Hz. A flow-rate reduction of about 18%(±3%) is typical when operating at 50 Hz.

PRESSURE: 27 feet (8.2 meters) of head pressure

WEIGHT: About 29 pounds (13 kg) in CPVC, depending on pump body length

MOTOR: Epoxy-coated, TEFC, Thermally Protected. Available in (specify voltage when ordering):

- Single phase, 3/4 HP (560 watt), 115/230 V, 9.6/4.8 A, 60 Hz, 3450 rpm.
- Single phase, 3/4 HP (560 watt), 110/220 V, 9.2/4.6 A, 50 Hz, 2850 rpm.
- Three phase, 1 HP (760 watt), 220/460 V, 3.0/1.5 A, 60 Hz, 3450 rpm. *Note: There is an additional charge for three-phase motors.*

RUNNING PUMP DRY DOES NOT DAMAGE MOTOR, PUMP, SEALS OR BEARINGS

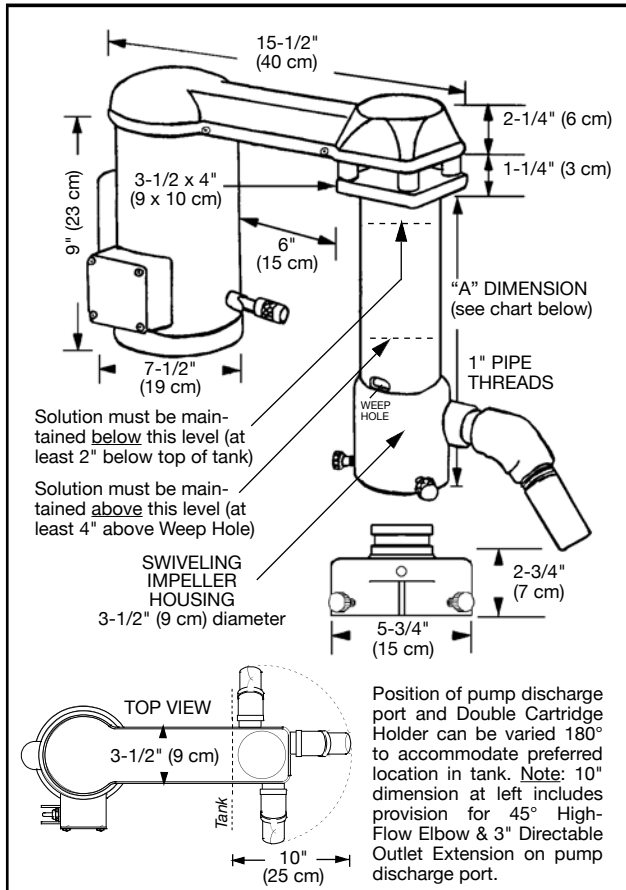
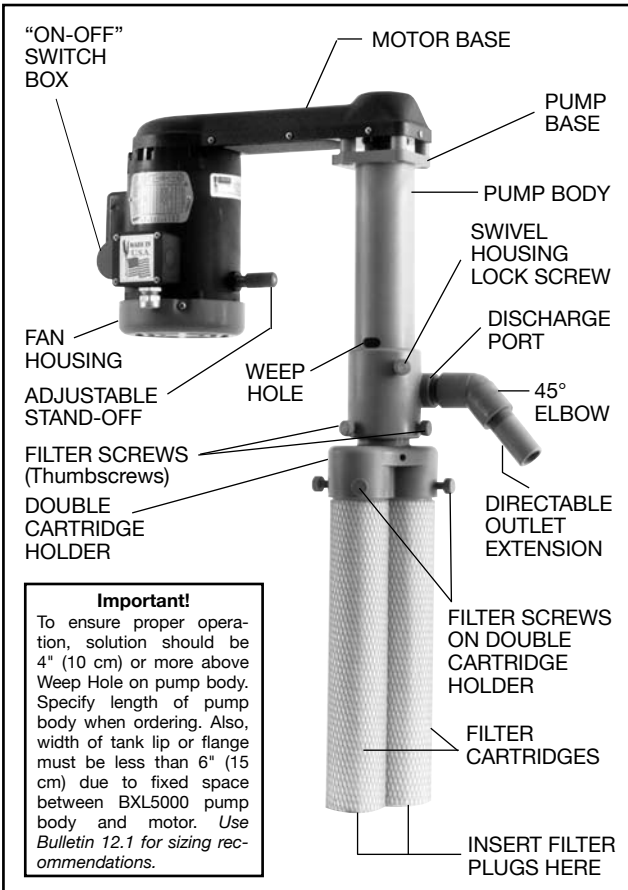

MEASUREMENT FROM BOTTOM OF PUMP BASE TO BOTTOM OF IMPELLER HOUSING ("A" DIMENSION)				
PUMP MODEL	BXL5000-8	BXL5000-10	BXL5000-12	BXL5000-14
"A" DIMENSION	10-3/4" (28 cm)	12-3/4" (32 cm)	14-3/4" (38 cm)	16-3/4" (43 cm)